

Chapter 8 – SCHEMATICS

Table of Contents

	Page No
Schematics (Table of Contents) .....	8-1
NHM-10 Audio .....	8-2
NHM-10 Aux. Power .....	8-3
NHM-10 Bluetooth .....	8-4
NHM-10 Camera .....	8-5
NHM-10 IR .....	8-6
NHM-10 Memories .....	8-7
NHM-10 Mjoelner .....	8-8
NHM-10 Power Amp .....	8-9
NHM-10 SIM & MC Connectors .....	8-10
NHM-10 System Connector .....	8-11
NHM-10 UEM .....	8-12
NHM-10 UI .....	8-13
NHM-10 UPP .....	8-14

Title: NHM-10 Audio

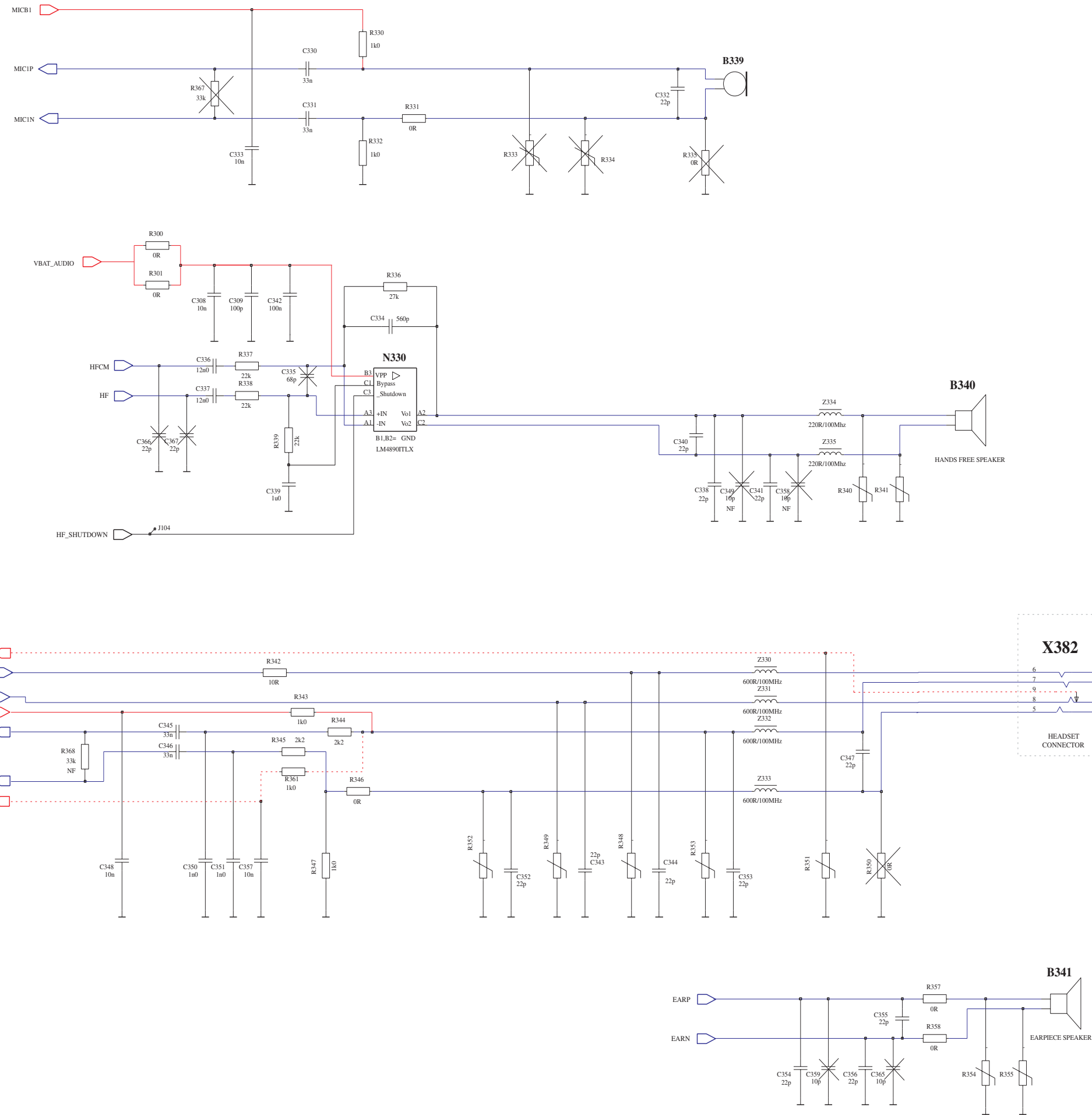

Title: NHM-10 Aux. Power

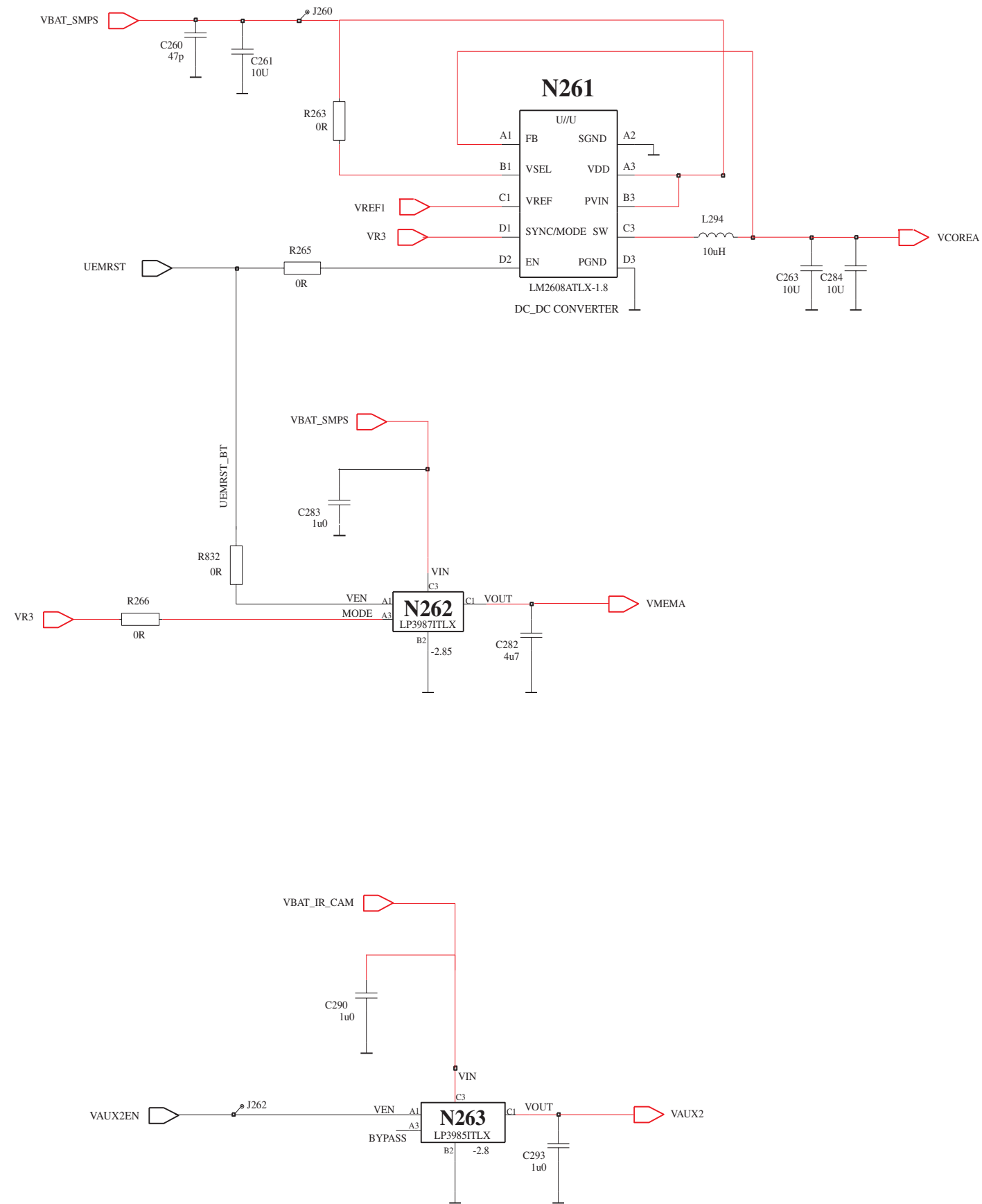

Title: NHM-10 Bluetooth

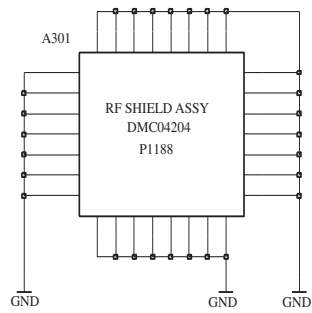
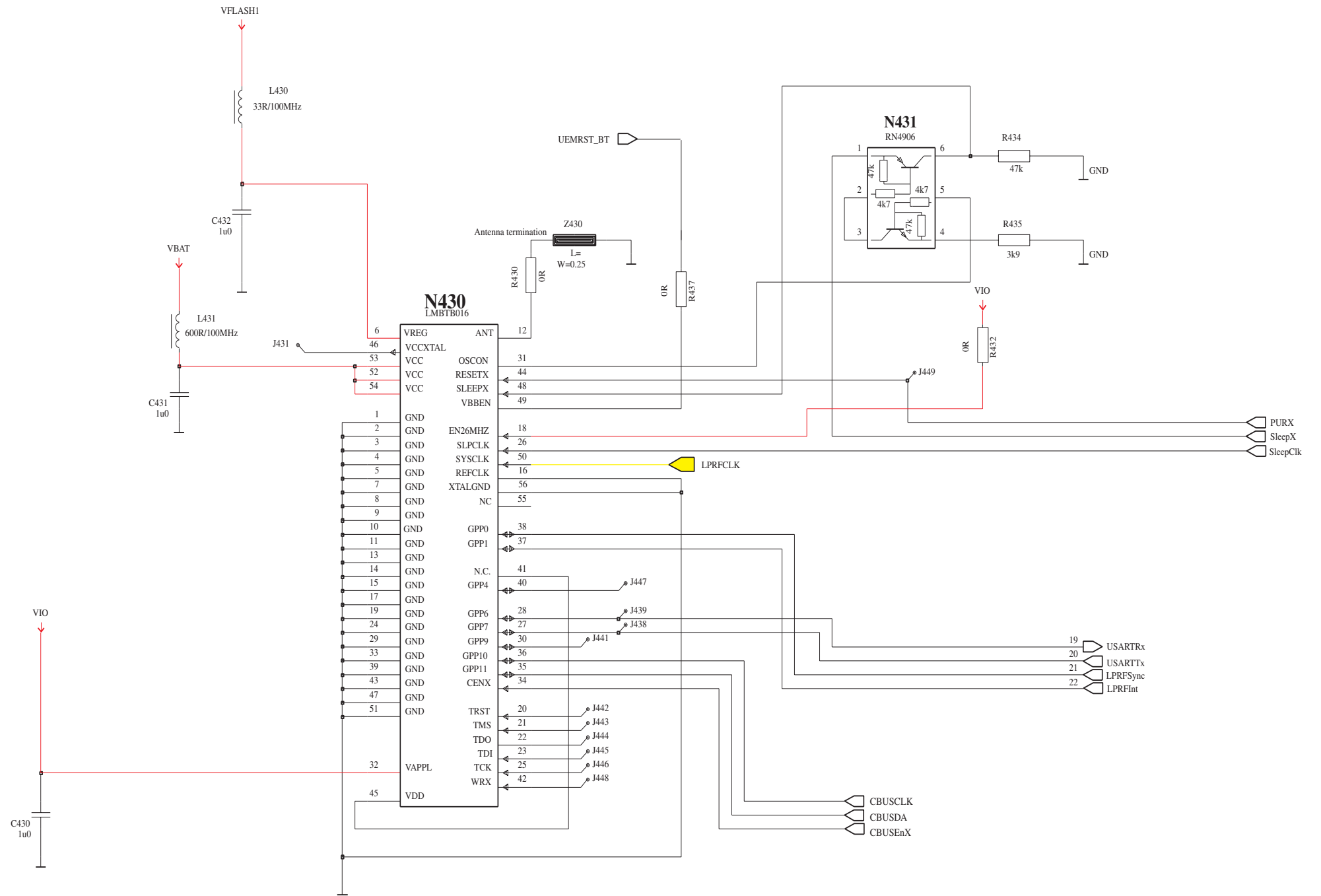

Title: NHM-10 Camera

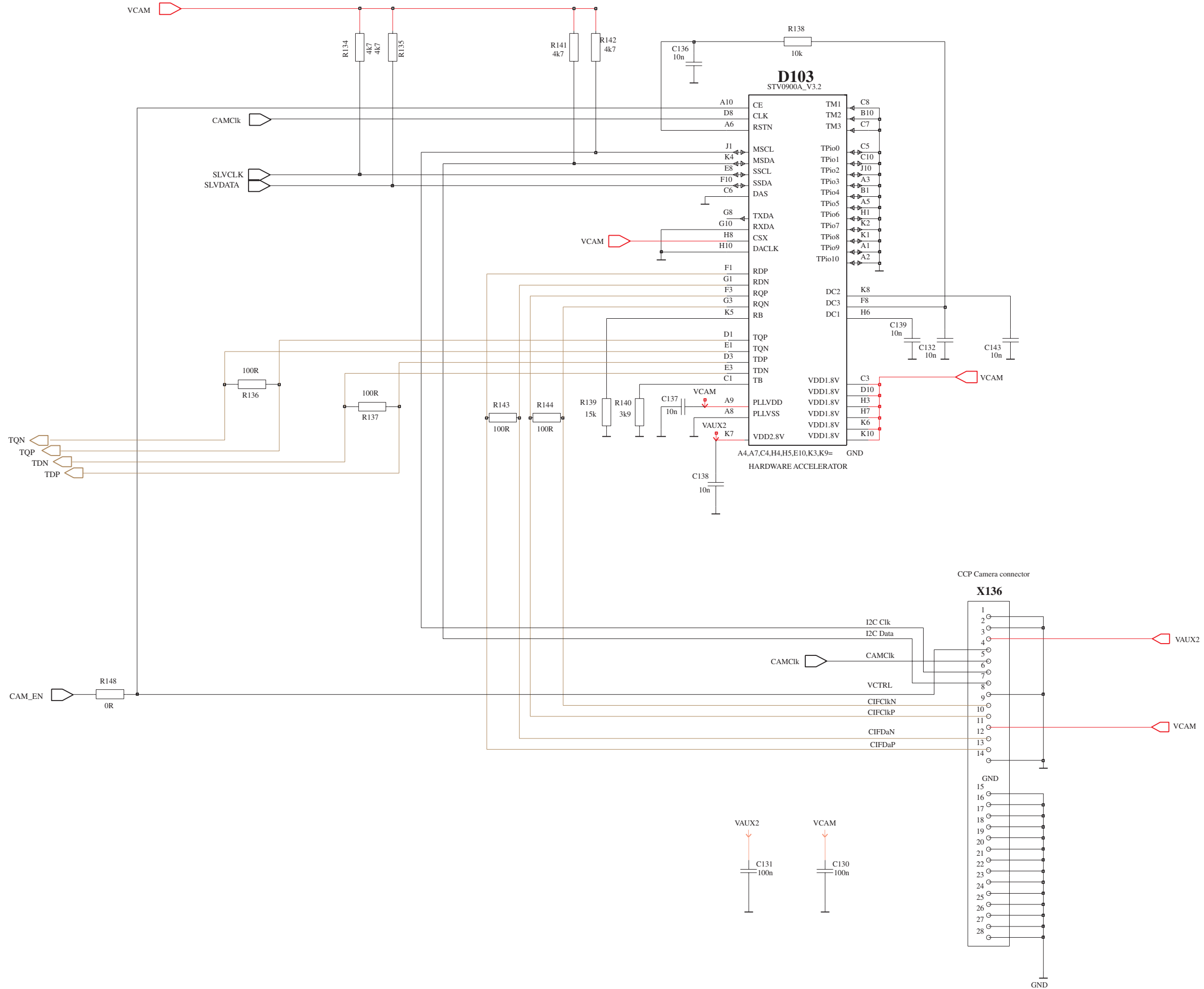

Title: NHM-10 IR

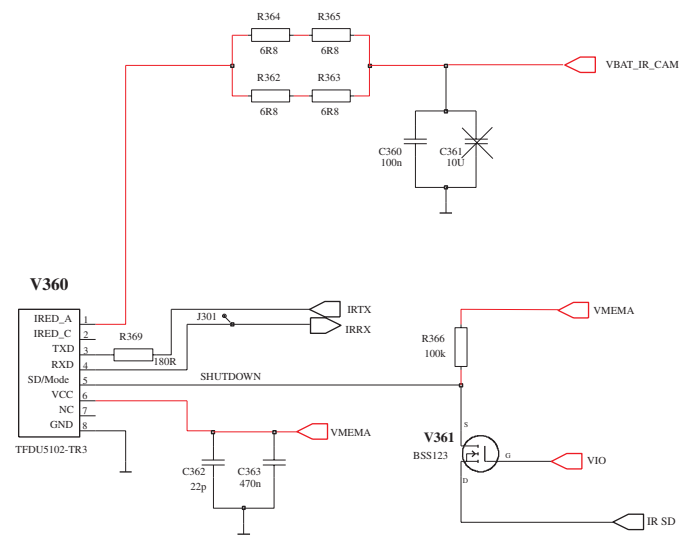

Title: NHM-10 Memories

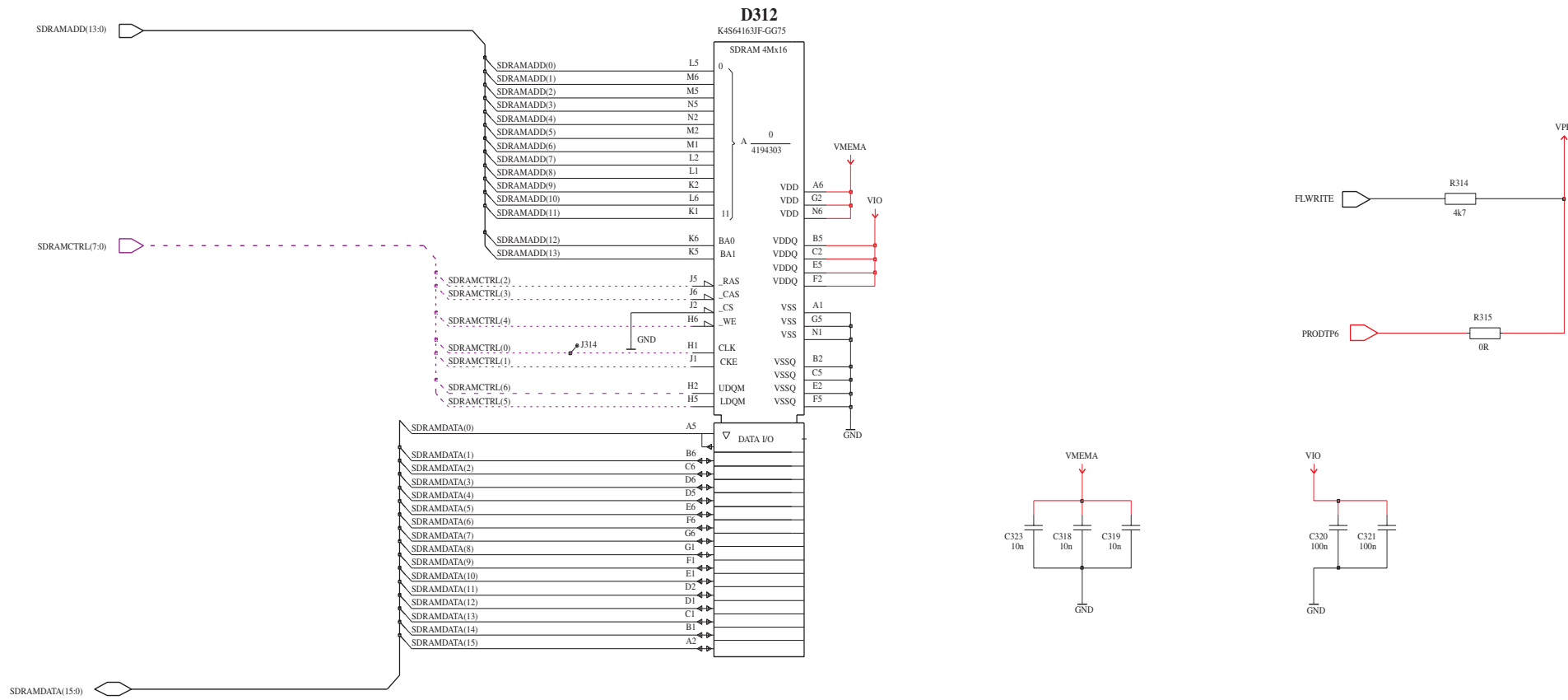
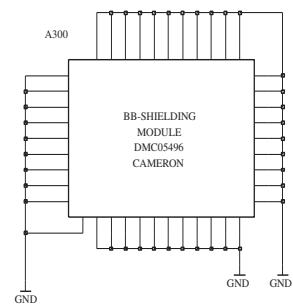
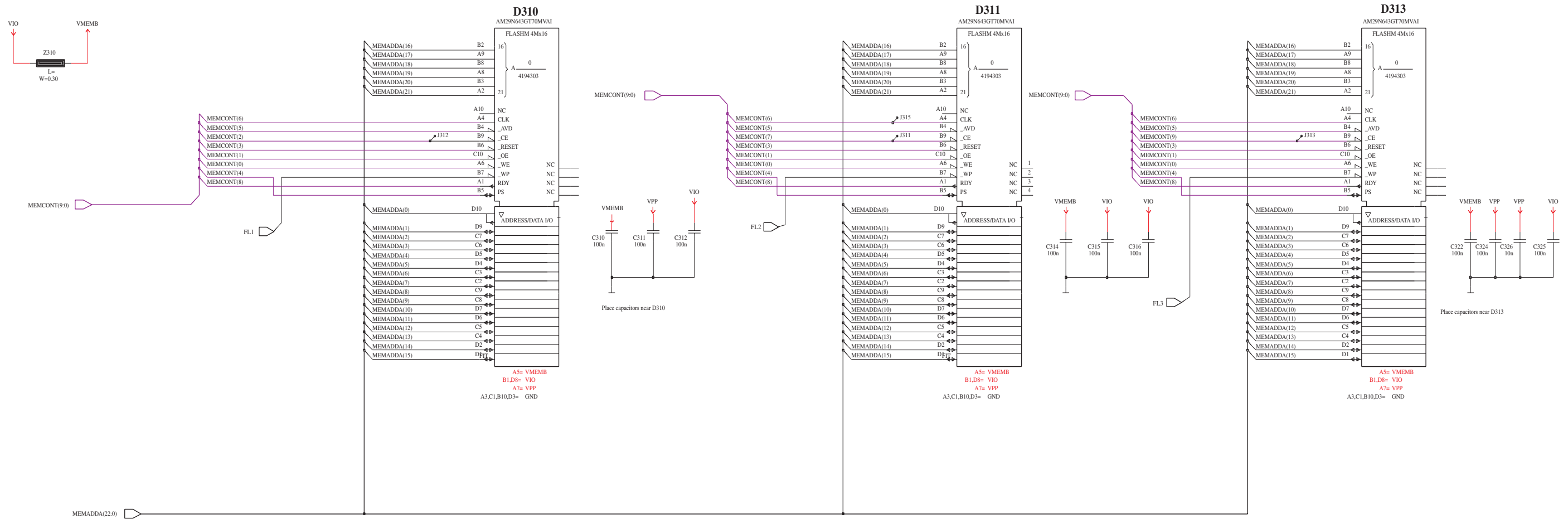





Title: NHM-10 Power Amp

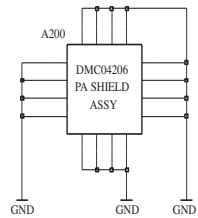
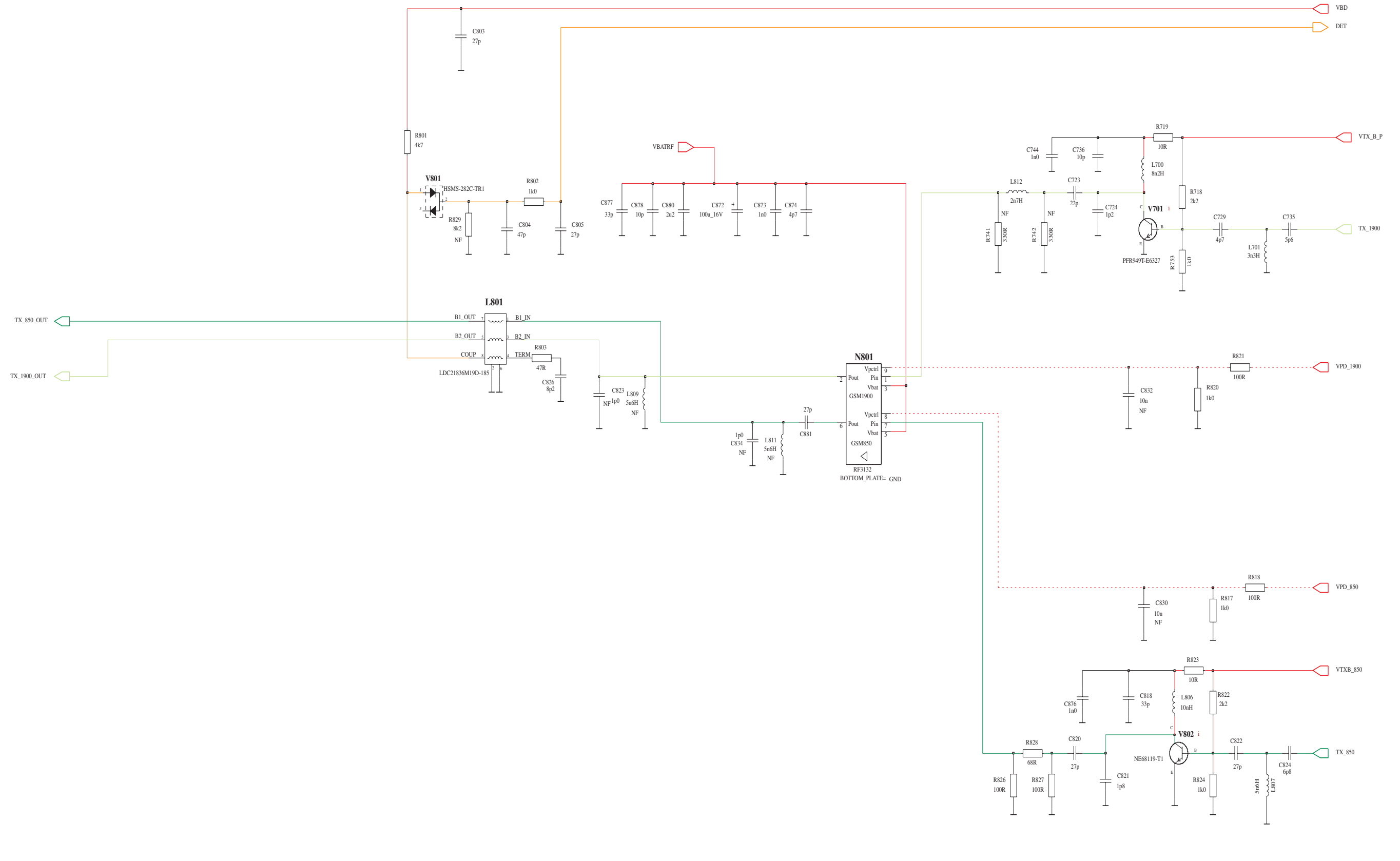

Title: NHM-10 SIM & MC Connectors

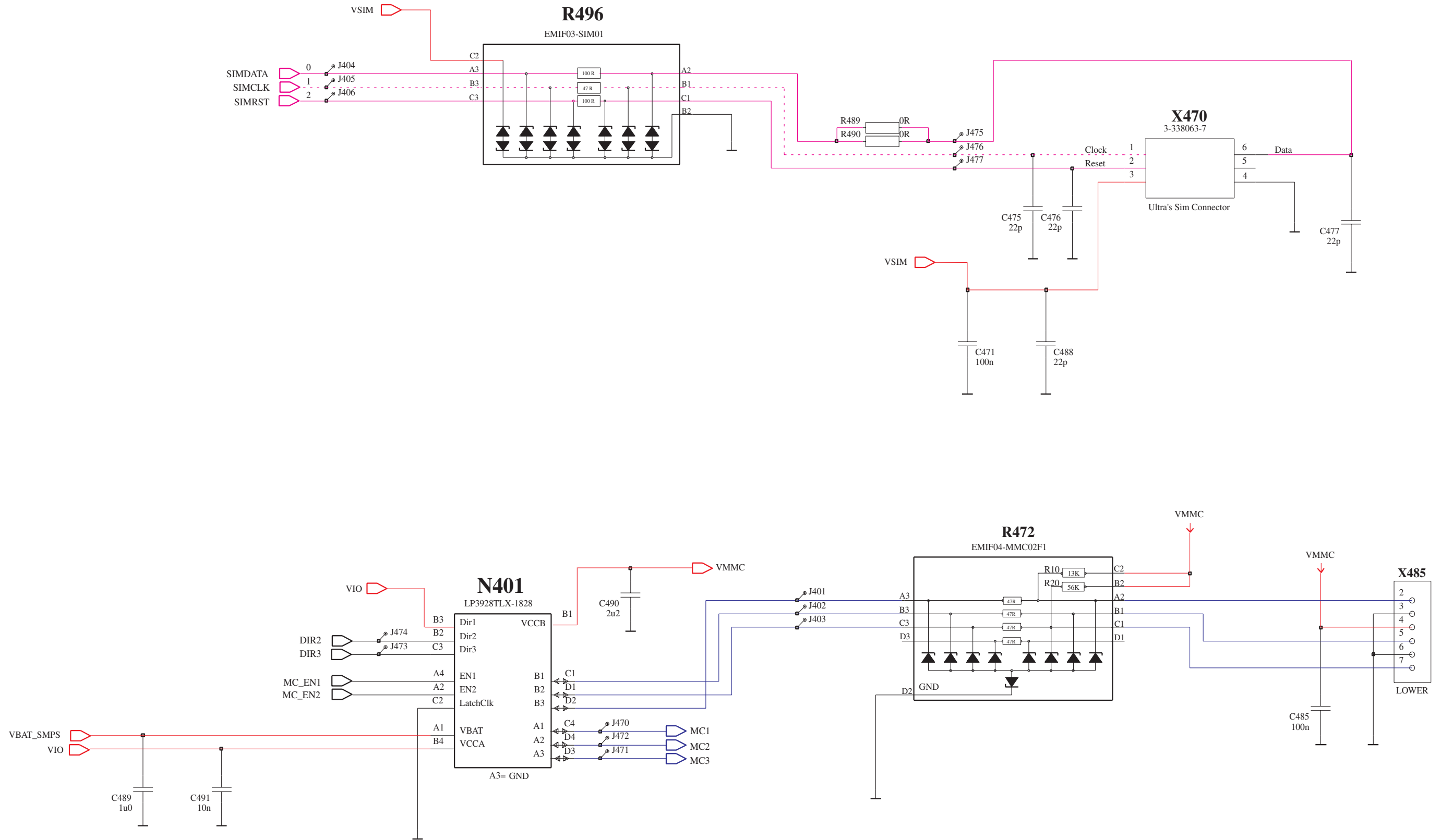

Title: NHM-10 System Connector

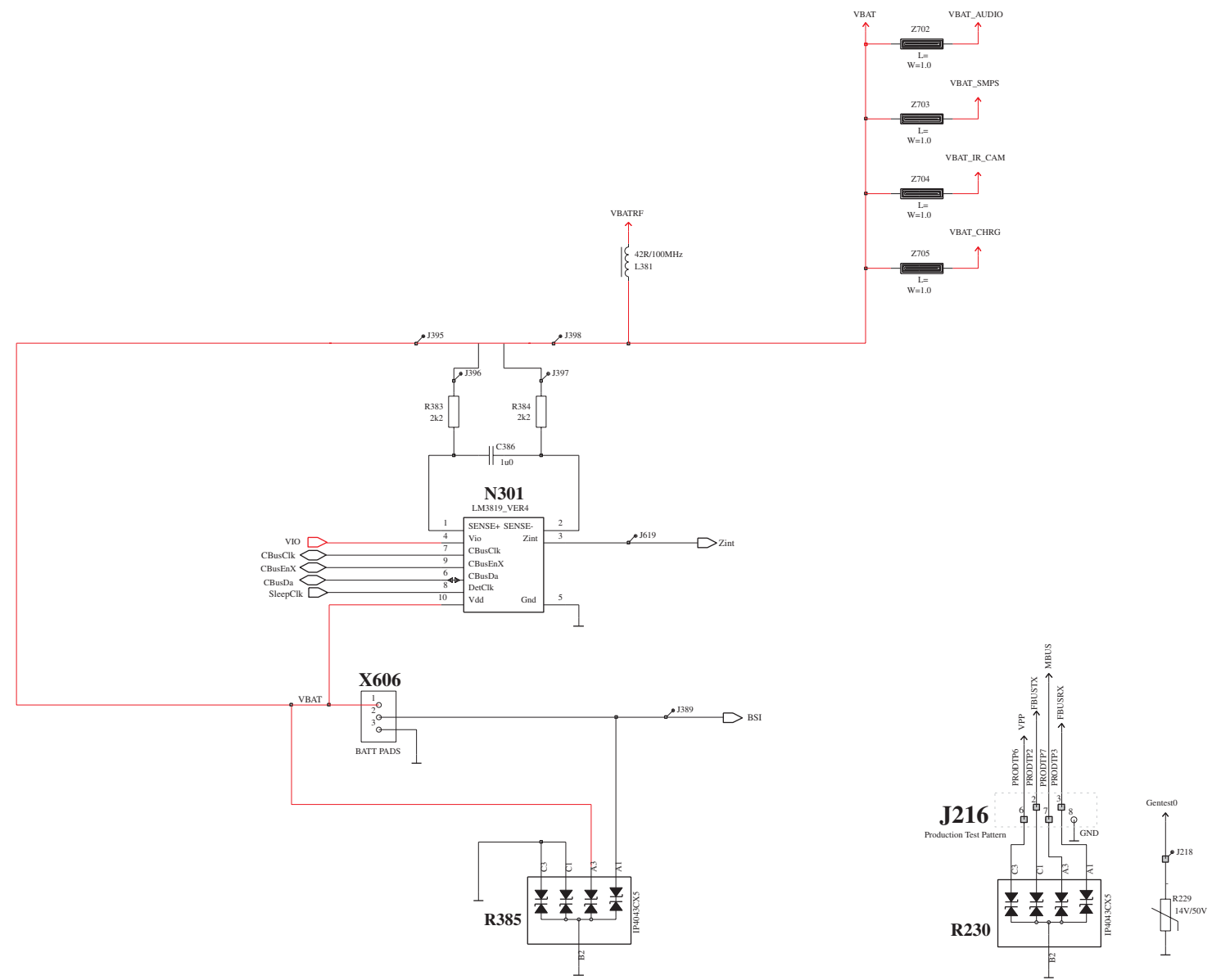

Title: NHM-10 UEM

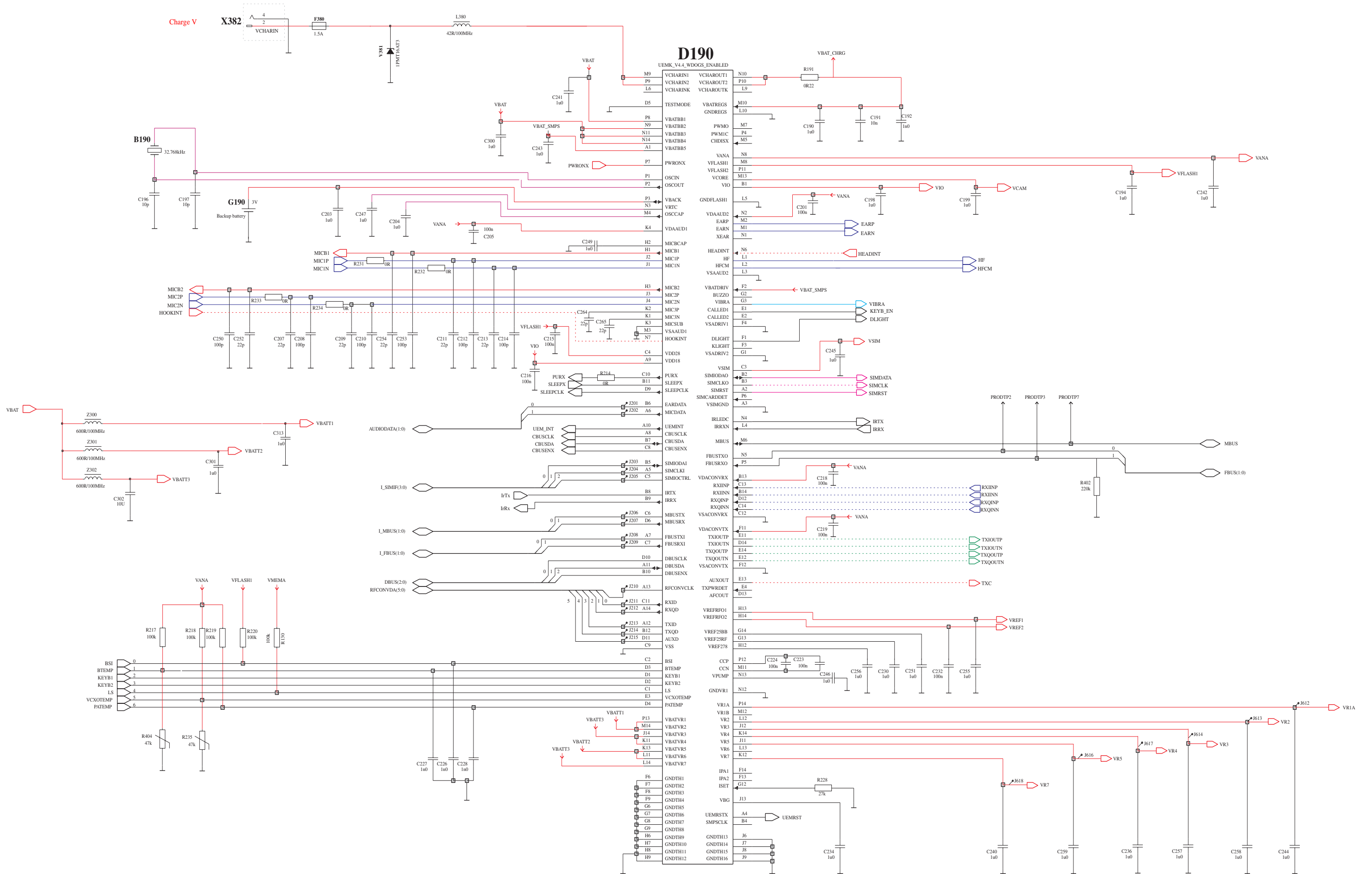

Title: NHM-10 UI

